

UNIVERSAL ATTACHMENT

CARTOP GEAR STOW

INSTRUCTIONS

- 1 Position the two Universal Attachment straps (A&B) over the two compression straps (C&D) on the Sherpak™ with the D-rings forward.
- 2 Unfasten the gutter hook strap from the ladder lock and run the free end through the Sherpak™ D-ring.
- 3 Making sure the gutter hook is facing the vehicle, run the gutter hook strap through the gutter hook.
- 4 Fasten the free end of the gutter hook strap through the ladder lock.
- 5 Repeat steps 1-4 so each end of the Universal Attachment straps are properly fastened to the Sherpak™.
- 6 Attach the gutter hooks to the vehicle gutters and cinch down the gutter hook strap.
- 7 After fastening the Sherpak™ to the vehicle with all four gutter hooks, stow the free end of the gutter hook strap behind the ladder lock to minimize strap slippage.

Note: We have provided ample slack in the gutter hook strap. Excess webbing can be cut off after you have properly sized the **Universal Attachment** to your vehicle.

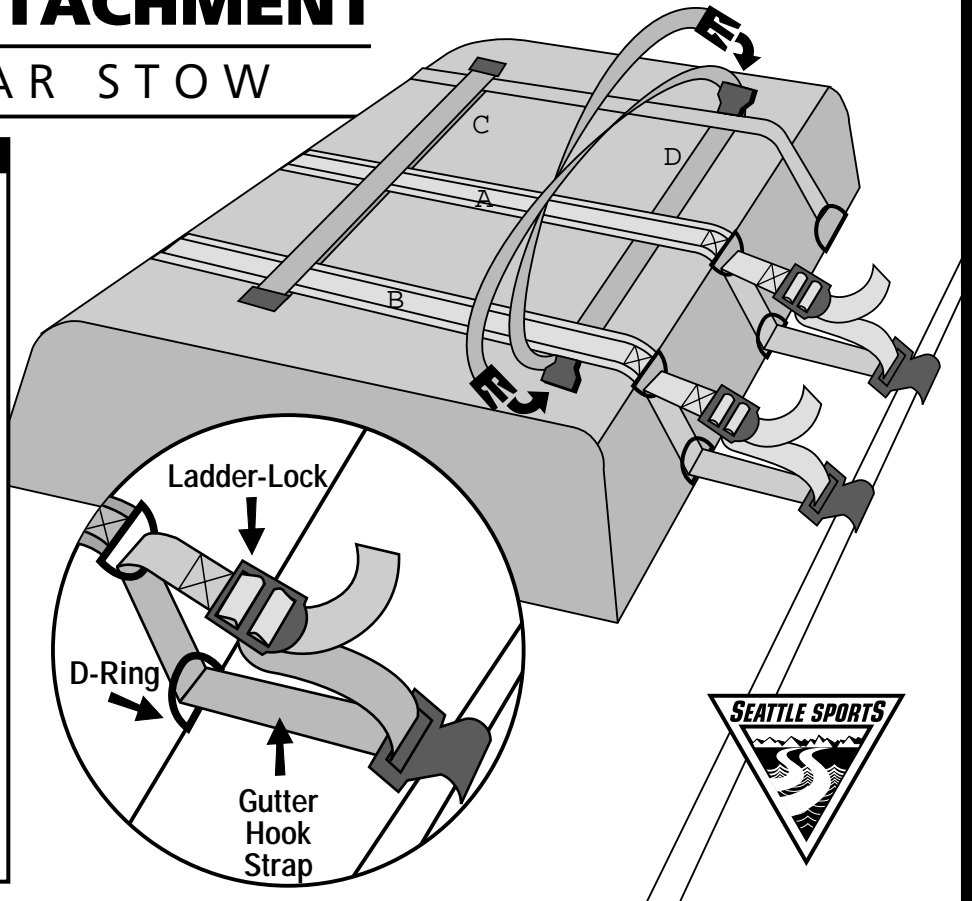

CONSUMER NOTE:

Follow all instructions on this sheet.

The **Universal Attachment** was designed as a simple accessory to attach a **Sherpak™** Car-Top Gear Stow to vehicles without a set of rack bars. This system's gutter hooks work on most vehicles with side rain gutters and will attach directly to some vehicle roofs by slipping between the top of the door and the vehicle roof.

However, Seattle Sports does not warrant the suitability of this **Universal Attachment** system for any particular vehicle. It is entirely the user's responsibility to determine the suitability of this system for his/her vehicle. Performance has been tested at legal speed limits only. User should use good judgment in determining the suitability of this product under extreme or unusual driving conditions. Webbing should be kept clean at all times to avoid damage to vehicle paint. If all straps are not kept tight, movement of the **Sherpak™** and straps may cause wear to vehicle paint.

LIMITED WARRANTY

This Seattle Sports product is guaranteed for material and workmanship for one year. The warranty is applicable only if all of the above instructions are followed and the product is used as recommended. The **Universal Attachment** is sold for use with the **Sherpak™** Car-Top Gear Stow only. This limited warranty is only applicable in conjunction with the instructions and warranty for the **Sherpak™** Car-Top Gear Stow.

The purchaser and/or user of this **Sherpak™** Car-Top Gear Stow acknowledges that Seattle Sports has no control over the attachment of its products to vehicles, nor does Seattle Sports have control over items which are loaded in the **Sherpak™**. Seattle Sports thus assumes no responsibility for any damage or injury to any person or property arising out of the improper attachment, use or loading of this **Sherpak™** Car-Top Gear Stow. The user has the sole responsibility to determine the suitability of this product for his/her vehicle.

This limited warranty is in lieu of all other warranties expressed or implied and does not cover consequential damages of any kind that may arise from the use or misuse of any Seattle Sports product.